

ACCESSIBILITY

BUILD IT RIGHT IOWA

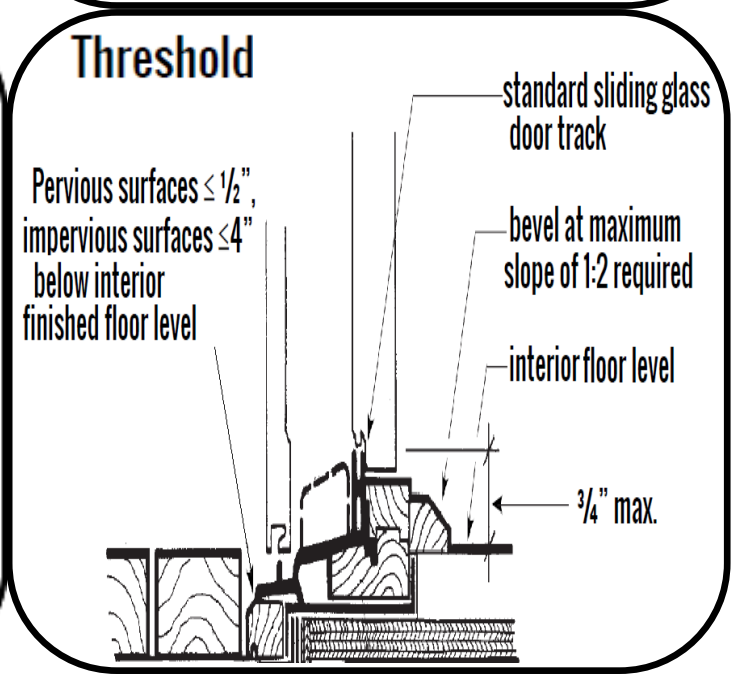
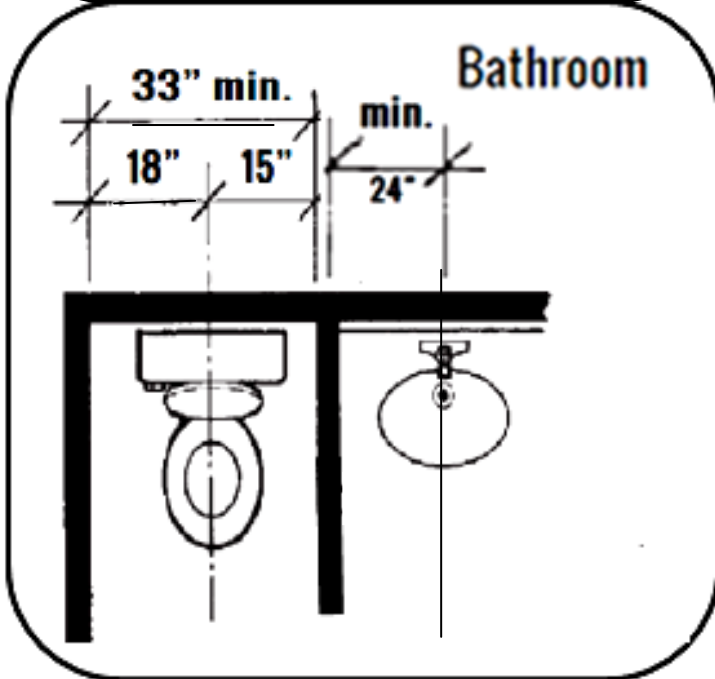
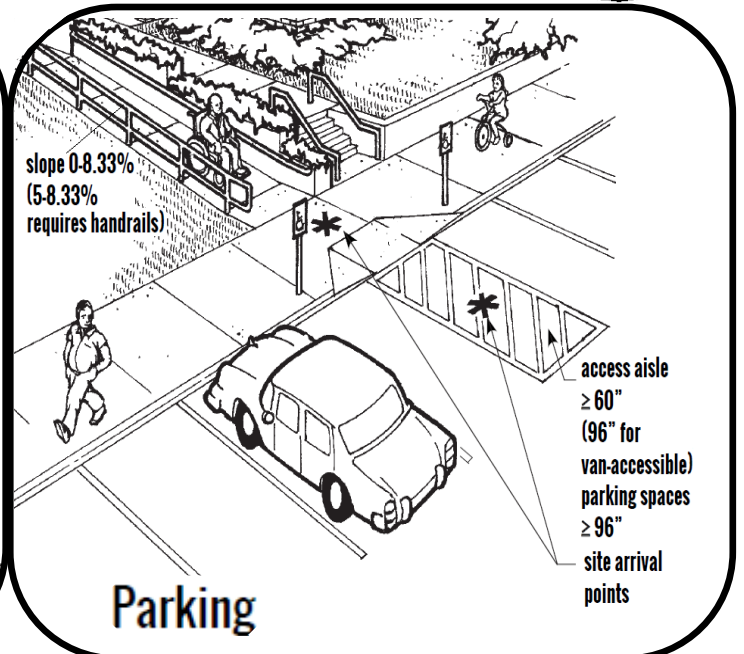
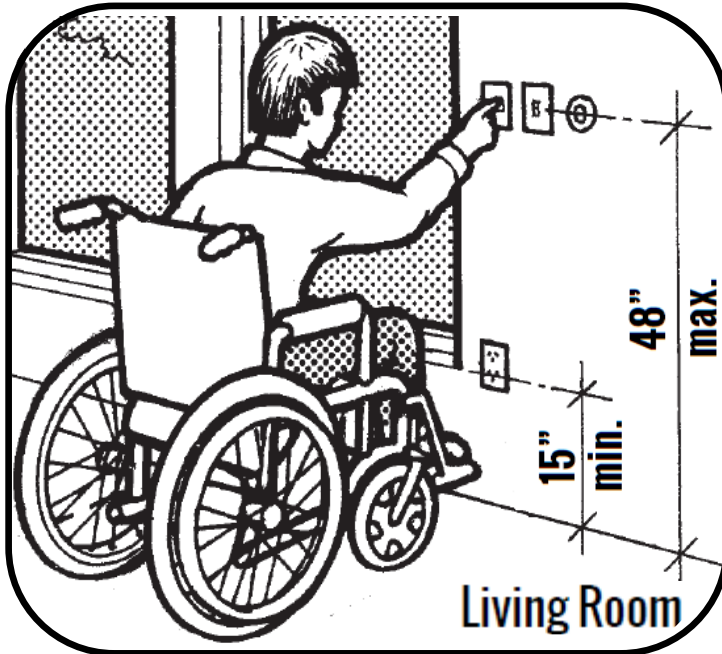

IOWA CIVIL RIGHTS COMMISSION

BUILD IT RIGHT IOWA EMAIL HOTLINE :

BUILDITRIGHTIOWA@IOWA.GOV

<https://icrc.iowa.gov/design-construction-build-it-right>

Emigdio López-Sanders

515-281-8046

Kerry Hainline

515-242-5556

QUICK CHECKLIST for Design & Construction Accessibility

Requirement 1- Accessible building entrance on an accessible route

- Sufficient number of parking spaces for persons with disabilities
- Access aisle 96" or wider for "van-accessible"
- Access aisle 60" or wider for "car-accessible"
- Curb ramp to sidewalk
- A stair-free route from parking lot to entrance
- Ramp slopes $\leq 8.33\%$

Requirement 2- Accessible and usable public and common use areas

- A stair-free route from parking and unit to all public/common use areas

Requirement 3- Usable doors

- Exterior doors $\geq 32"$
- Interior and patio doors $\geq 31\text{-}5/8"$
- Grasp-free lever on primary exterior door

Requirement 4- Accessible routes into and through covered unit

- All hallways $\geq 36"$ wide
- Low or no threshold on all doorways

Requirement 5- Light switches, electrical outlets, thermostats, and other environmental controls in accessible locations

- All wall-mounted fixtures located between 15" and 48" from the finished floor

Requirement 6- Reinforced walls in bathrooms for later installation of grab bars

- Walls surrounding toilet, bathtub, and shower are reinforced with blocking

Requirement 7- Usable Kitchens and Bathrooms

- Distance between wall and midline of sinks or stoves $\geq 24"$
- Distance between counters in kitchen $\geq 40"$