

# PREDETERMINATION SETTLEMENT AGREEMENT

CP# 10-17-71050  
HUD# 07-18-7632-8

PARTIES TO THE SETTLEMENT AGREEMENT:

RESPONDENTS

**JOHNSTON MERLE HAY & 57TH, L.L.C.**  
C/O CRAIG REID – PERRY REID PROPERTIES  
9200 Andermatt Drive  
Lincoln, Nebraska 68526-9639

**DALLENBACH LARSON DEVELOPMENT, L.L.C.**  
**ATTN: STEVEN DALLENBACH**  
P.O. Box 267  
Johnston, Iowa 50131-0267

**ALLER DESIGN GROUP, L.L.C.**  
1840 NW 118<sup>th</sup> Street, Suite 220  
Clive, Iowa 50325-8275

COMPLAINANT

**ANGELA JACKSON, COMMISSIONER**  
Iowa Civil Rights Commission  
400 East 14<sup>th</sup> Street, Room 201  
Des Moines, Iowa 50319-0201

and

**IOWA CIVIL RIGHTS COMMISSION**  
400 East 14<sup>th</sup> Street, Room 201  
Des Moines, Iowa 50319-0201

## Complainant's Allegations:

Complainant is a member of the Iowa Civil Rights Commission (ICRC). As a member, Complainant has the authority to file a complaint alleging a discriminatory practice in violation of the "Iowa Civil Rights Act of 1965," Iowa Code Chapter 216. Complainant alleged Respondents designed and constructed covered multifamily dwellings in violation of the design and construction accessibility requirements of the Iowa Civil Rights Act (ICRA) and the federal Fair Housing Act (FHA). Complainant alleged Respondents violated the

“accessible and usable public and common use areas,” the “light switches, electrical outlets, thermostats, and other environmental controls in accessible locations,” and “usable kitchens and bathrooms.”<sup>1</sup>

Complainant specifically alleged, in Unit 107, 5719 NW 57<sup>th</sup> Avenue, Johnston Gardens Apartments (“Johnston Gardens”), two features in the common areas and three features within one of the covered ground-floor units appeared inaccessible to a person utilizing a wheelchair for mobility – (1) the heights of the midlines of the keyholes at the mailbox compartments assigned to Units 101 and 102 at the kiosks each of the three buildings were measured at 58” (Unit 101), and 55” (Unit 102) – all of which are higher than the 54”-maximum allowed for a parallel approach by persons using a wheelchair; (2) the height of the curb in front of the mailbox kiosks is at least 5” – which is greater than the ¼”-maximum allowed by ANSI for changes in level along accessible routes – and the loose gravel to the left and right of the kiosks – which does not meet ANSI’s requirement for a “stable, firm, and slip-resistant” surface – render the mailbox kiosks inaccessible to persons using a wheelchair; (3) the clearance from the midline of the sink to the wall in Unit 107 was measured at 21 3/16”, which is less than the 24-inch clearance required for a parallel approach needed because the sink was not removable; and (4) the height of the thermostat top controls in Unit 107 was measured at 54”, which is more than the allowed maximum height of 48”.

Description of the Subject Property

Subject Property

Johnston Gardens consists of three buildings – 5705 NW 57<sup>th</sup> Avenue, 5713 NW 57<sup>th</sup> Avenue, and 5719 NW 57<sup>th</sup> Avenue.<sup>2</sup> The three residential buildings and common areas will be required to meet the same accessibility requirements of the ICRA and FHA. The certificate for Building 5719 [tested building] was issued on December 14, 2016; for Building 5705 on May 18, 2017; and for Building 5713 on June 27, 2017, which were signed by Douglas Sandvig, Building Official for the City of Johnston.

The scope of the current agreement includes all of the dwelling units and the public and common use areas, including the leasing office, dumpsters, and the mailbox kiosks adjacent to the main entrance to the subject property.

The dwelling units at Johnston Gardens consist of three floor-plan types.<sup>3</sup> The table below lists the unit floor-plan type, each tested unit’s building and number, the total number of units of each floor-plan type by building, and total number of units of each floor-plan type.

Unit Type	Inspected Building Numbers/ Unit Numbers	Total Units Per Type by Building	Total Units Per Type
A	5719 / 107	2	6
B	5713 / 104	4	12
C	5719 / 108	2	6
	<b>GRAND TOTALS</b>	12	24

<sup>1</sup> See Iowa Code §§216.8A(3)(e)(3)(a) [Requirement 2 – Accessible and Usable Public and Common Use Areas]; 216.8A(3)(e)(3)(c)(ii) [Requirement 5 – Light Switches, Electrical Outlets, Thermostats, and Other Environmental Controls in Accessible Locations]; and 216.8A(3)(e)(3)(c)(iv) [Requirement 7 – Usable Kitchens and Bathrooms].

<sup>2</sup> Henceforth, the buildings will be referred to as “Building 5705,” “Building 5713,” and “Building 5719.”

<sup>3</sup> See Appendix B for floor plans.

## Respondents' Defenses

When asked in the questionnaire what was true or false about the allegations, all Respondents answered:

1. We would like to schedule a site visit at the property with Iowa Civil Rights inspector to verify accessibility compliance or issues that may need resolved.
2. See above

## Report of Preliminary Findings:

ICRC Investigators inspected 8 units at Johnston Gardens, as well as the public and common use areas in and surrounding the complex. After conducting an onsite inspection of the units listed in the table above, and the public/common use areas, ICRC Investigators found and reported the following deficiencies:

1) At both parking spaces reserved for persons with disabilities adjacent to Building 5719, the height to the bottom edge of the signage was measured at 46 ¼” which is less than the minimum height of 60 inches allowed by ADAAG.<sup>4</sup> Although both parking spaces and adjoining access aisle were observed at Building 5719 – which meet the required ADA dimensions for Van-Accessible parking spaces and access aisles – neither of the two parking spaces had the required signage designating each as “Van-Accessible.”<sup>5</sup>

The plans submitted by Respondents include instructions for the installation of signage designating spaces as reserved for persons with disabilities. The relevant instructions for the installation of these signs are shown below.

4. SIGNS, PROVIDE THE FOLLOWING:
  - A. PROVIDE VAN ACCESSIBLE PARKING SIGNAGE AS PER ADAAG REQUIREMENTS.<sup>6</sup>

Based on these instructions, the height to the bottom edge of the signage designating the accessible parking spaces as reserved for persons with disabilities was designed to comply with ADAAG requirements – which include a minimum height of 60” to the bottom edge of the signs and signage designating at least one of these two parking spaces as “Van-Accessible.” However, as installed, the signage at both parking spaces (1) was installed too low – making the spaces more challenging to locate; and (2) neither one of these two parking spaces had the required “Van-Accessible” signage – making the identification of parking spaces wide enough for vans more challenging.

2) The mailboxes for all 72 units at Johnston Gardens are housed within five mailbox kiosks, which are located near the main entrance to the subject property.<sup>7</sup> None of the buildings at Johnston Gardens has an elevator. Therefore, only the mailboxes for the ground-floor units must meet reachability requirements.

There is sufficient clearance in front of all mailbox kiosks to allow for a parallel approach by persons using a mobility-assistive device such as a wheelchair. The height from the concrete pad where the kiosks are installed to the midline of the keyholes at the top two rows of mailboxes measured 54 ½”, which exceed

---

<sup>4</sup> See Appendix A, Photo 1A.

<sup>5</sup> See Appendix A, Photos 1B and 1C.

<sup>6</sup> See Appendix B.

<sup>7</sup> See Appendix A, Figure 3A for location of mailbox kiosks as captioned in the site plans.

the 54"-maximum allowed for a parallel approach by ANSI 1986. However, there is a 6 1/8" high curb. This curb creates an obstruction in front of the mailbox kiosks, which has a horizontal projection to mailboxes that was measured at no less than 36". So, even without regards to their heights, the mailboxes are rendered unreachable by virtue of the 36"-depth of the obstruction, which exceeds the 24"-maximum allowed in ANSI 1986 by 12".<sup>8</sup>

The plans submitted by Respondents include instructions for the installation of mailboxes, which are shown below.

**NOTE:  
MAILBOXES SHALL BE WITHIN DISABLED REACH RANGES PURSUANT TO  
FHA REQMNT.<sup>9</sup>**

Based on these instructions, the heights to the midline of the keyholes of the mailbox compartments were designed to comply with FHA requirements. Also in their plans, Respondents included instructions and diagrams about the technical requirements for reachability, which are shown below:

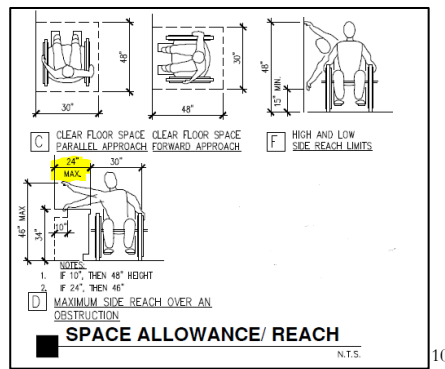

Based on these instructions and diagram, the distance required to reach operable fixtures, including mailboxes, was designed to be no more than 24". However, as installed, the distance required to reach the mailboxes exceeds the 24" maximum by 12". Each of these factors – the horizontal projection of the obstruction caused by the change in level in the curb and the height of the top two rows of mailboxes – render these mailboxes inaccessible to persons using wheelchairs for mobility.

3) The height of the top control buttons of the thermostats in all inspected units was measured at 54 1/8", which exceeds the 48"-maximum height.<sup>11</sup>

The plans submitted by Respondents included the following instructions and diagrams for the installation of the thermostats:

<sup>8</sup> See Appendix A, Photos 2C, 2D, and 2E.

<sup>9</sup> See Appendix B.

<sup>10</sup> *Id.*

<sup>11</sup> See Appendix A, Photo 3A.

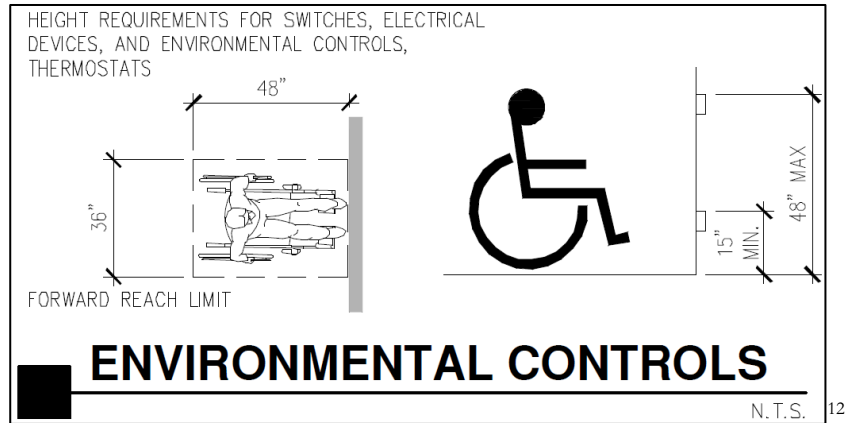

The heights of the thermostats in these inspected units would have been compliant with the 48"-maximum height requirement as referenced above if installed according to the plans. But, as built, they are too high, rendering them unusable by persons using wheelchairs.

4) ICRC agrees with Respondents' assertion that the cabinets are removable, as based on (1) Respondents statements; (2) the product specification sheets submitted by Respondents; (3) the compliance of the dimensions measured by ICRC Investigators of the knee and toe space under the sink; and (4) ICRC Investigator's inspection of the cabinet. The midline of the sink in the Master Bathroom was measured at 21". Since a forward approach to the bathroom sink is possible due to the cabinet meeting being removable, the bathroom sinks are determined to comply with the 15"-minimum clearance to the closest obstruction. Therefore, the additional information gathered during the inspection did not support the allegation that the bathroom sinks were too close to the adjacent wall.

Additionally, ICRC Investigators measured the height of the bathroom sinks. In bathroom sinks with removable cabinets installed at Specification-B bathrooms, the Guidelines require the height to the top of the rim at the sink to be no more than 34", as shown below:

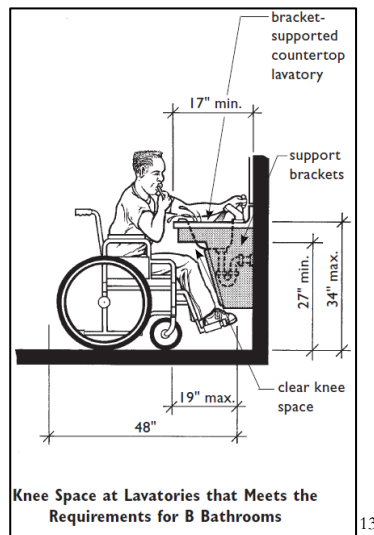

<sup>12</sup> See Appendix B.

<sup>13</sup> See Manual at page 7.52.

The height of the bathroom sinks in all inspected units was measured at no less than 36 3/4", which exceeds the 34"-maximum height allowed by the Guidelines.<sup>14</sup>

The plans submitted by Respondents included the following instructions and diagrams for the installation of the bathroom sinks:

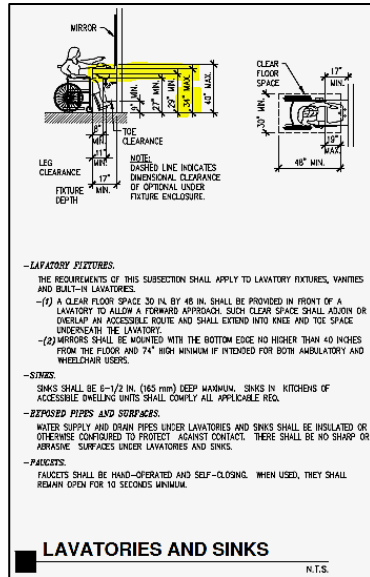

15

The heights of the bathroom sinks in all inspected units would have been compliant with the 34"-maximum height requirement as referenced above if installed according to the plans. But, as built, they are too high, rendering them unusable by persons using wheelchairs.

5) The heights of the bathroom towel bars in all inspected units were measured at no less than 54 1/2", and were installed above toilets which have a depth of 28". Therefore, the towel bars will need to be moved to a different wall at a height of no more than 54" if there are no obstructions because the depth of the toilet exceeds the maximum depth for obstructions.

The heights of the towel bars in these inspected units were not designed or built to be compliant with maximum height requirements. As built, the towel bars are too high, rendering them unusable by persons using wheelchairs.<sup>16</sup>

### Respondents' Response to Report of Preliminary Findings:

Respondents submitted the following responses to the reported deficiencies:

1) Respondents will raise the signage at both parking spaces adjacent to Building 5719 that are reserved for persons with disabilities.

<sup>14</sup> See Appendix A, Photo 4A.

<sup>15</sup> See Appendix B.

<sup>16</sup> See Appendix A, Photo 5A.

- 2) Respondents will (i) move the mailbox kiosks to either the front of the curb adjacent to the current location or to the front of one of the buildings; and (ii) coordinate with the United States Postal Service to reassign the mailbox compartments, such that the mailboxes of all ground-floor units will be at or below the 54"-maximum height above the parking surface.
- 3) Respondents will relocate the thermostats to decrease the height to the highest operable control to no more than the 48"-maximum height.
- 4) Respondents will replace the removable vanity cabinets – which have sink rims at heights exceeding the 34"-maximum – with shorter removable cabinets to decrease the height of the sink rims to no more than 34".
- 5) Respondents will relocate towel bars to a different wall away from the toilet, and at a height of no greater than 54".

#### Assessment of Deficiencies:

Respondents stated in their written responses to the ICRC questionnaire According to the plans submitted by Respondents, all units were built in accordance with the scoping requirements of the 2012 International Building Code [IBC 2012], which incorporates the standards of the 2009 American National Standards [ANSI 2009] for guidance on the technical requirements [i.e., the dimension requirements]. Neither the IBC 2012 nor the ANSI 2009 is one of the safe harbors accepted by HUD.<sup>17</sup> Therefore, the Manual and the Guidelines, which incorporate ANSI 1986 for some of the technical requirements, must be used to assess and determine compliance with the ICRA and FHA, not IBC 2012 or ANSI 2009.

The public areas must meet the requirements of the ADA in addition to those of the FHA, as people other than residents or residents' visitors will visit or frequent those areas. The common use areas, however, such as the exterior parking spaces and sidewalks adjacent to Buildings 5705 and 5713, mailbox kiosks, and dumpsters by the FHA since they are only for use by the residents of Johnston Gardens and their guests. The ADA will only be referenced in the current agreement for the public areas, which include leasing office, exterior parking spaces and sidewalks adjacent to Building 5719 – where the leasing office is located – and the hallways.<sup>18</sup> Finally, the requirements of the ADA will be presented as stated in the "2010 American with Disabilities Act Standards: 2004 ADAAG for Titles II and III Facilities" (ADAAG). *See* 42 U.S.C. 12204, Part 1191, Appendix A, and 42 U.S.C 12186(b); 28 CFR Part 36, Appendix B.

Following is the assessment of Respondents' proposed retrofits, based on the scoping and technical requirements of the 2010 ADAAG, the Manual, and ANSI 1986:

- 1) ICRC concurs with Respondents' proposal to reinstall the signage at both parking spaces designated as reserved for use by persons with disabilities – that are adjacent to Building 5719 – at a greater height such that the height to the bottom edge of the signage is compliant with the 60"-minimum height requirement. ICRC will also require that the "Van-Accessible" signage be added to one of the parking spaces in

---

<sup>17</sup> <http://www.fairhousingfirst.org/faq/safeharbors.html> (Last visited on March 28, 2014).

<sup>18</sup> The ADAAG defines "Public Use" as "[I]nterior or exterior rooms or spaces that are made available to the general public. Public use may be provided at a building or facility that is privately or publicly owned." *See* "Definitions" on page 47 of ADAAG available online at [http://www.ada.gov/regs2010/2010ADASTandards/2010ADASTandards\\_prt.pdf](http://www.ada.gov/regs2010/2010ADASTandards/2010ADASTandards_prt.pdf). Therefore, since the hallways and parking spaces are available for use by prospective residents, who are part of the general public, these areas are deemed to be "Public Use."

compliance with the same 60”-minimum height to the bottom edge of the signage. ICRC will require that this modification be completed within 60 days of the date of the Closing Letter from ICRC.

- 2) ICRC concurs with Respondents’ proposal to move the mailbox kiosks to either the front of the curb adjacent to the current location or to the front of one of the buildings; and (ii) coordinate with the United States Postal Service to reassign the mailbox compartments, such that the mailboxes of all ground-floor units will be at or below the 54”-maximum height. ICRC will require that this modification be completed within 60 days of the date of the Closing Letter from ICRC.
- 3) ICRC concurs with Respondents’ proposal to relocate the thermostats to decrease the height of the highest operable control to no more than the 48”-maximum height allowed by ANSI 1986. ICRC will require that this modification be completed within one year of the date of the Closing Letter from ICRC or sooner if requested by a tenant with a disability.
- 4) ICRC concurs with Respondents’ proposal to replace the removable vanity cabinets – which have sink rims at heights exceeding the 34”-maximum – with shorter cabinets to decrease the height of the sink rims to no more than 34”. ICRC will require that this modification be completed within one year of the date of the Closing Letter from ICRC or sooner if requested by a tenant with a disability.
- 5) ICRC concurs with Respondents’ proposal to relocate towel bars to a different wall from the wall behind the toilet and at a height of no greater than 54”, as long as the new location allows for a parallel approach to the towel bar. ICRC will require that this modification be completed within 60 days of the date of the Closing Letter from ICRC.

#### Predetermination Settlement Agreement

A complaint having been filed by Complainant against Respondents with ICRC under Iowa Code Chapter 216 and there having been a preliminary inquiry, including an on-site inspection of the subject property, the parties do hereby agree and settle the above-captioned matter in the following extent and manner:

#### *Acknowledgment of Fair Housing Laws*

- 1) Respondents agree there shall be no discrimination, harassment, or retaliation of any kind against Complainant or any other person for filing a charge under the “Iowa Civil Rights Act of 1965” (ICRA); or because of giving testimony or assistance, or participating in any manner in any investigation, proceeding or hearing under the ICRA; or because of lawful opposition to any practice forbidden by the ICRA. Iowa Code § 216.11(2).
- 2) Respondents acknowledge the ICRA makes it unlawful to discriminate in the terms, conditions or privileges of sale or rental of a dwelling or in the provision of services or facilities in connection with the dwelling because of race, color, creed, sex, sexual orientation, gender identity, national origin, religion, disability, or familial status. Iowa Code § 216.8(1)(b).
- 3) Respondents acknowledge the ICRA makes it unlawful to sell, rent, lease, assign, sublease, refuse to negotiate, or to otherwise make unavailable, or deny any real property or housing accommodation or part, portion, or interest therein, to any person because of the race, color, creed, sex, sexual orientation, gender identity, religion, national origin, disability, or familial status of such person. Iowa Code § 216.8(1)(a).



- 4) Respondents acknowledge the Fair Housing Act (FHA) makes it unlawful to sell, rent, lease, assign, sublease, refuse to negotiate, or to otherwise make unavailable, or deny any real property or housing accommodation or part, portion, or interest therein, to any person because of the of race, color, religion, sex, familial status, or national origin. 42 U.S.C. 3604(f)(1)(a) (§ 804(f)(1) of the Fair Housing Act).
- 5) Respondents acknowledge the FHA and ICRA make it unlawful to refuse to make reasonable accommodations in rules, policies, practices, or services, when the accommodations are necessary to afford the person equal opportunity to use and enjoy a dwelling and to the extent that the accommodation does not cause undue financial or administrative burden or fundamentally alter the nature of the provider's operations. 42 U.S.C. 3604(f)(3)(b) (§ 804(f)(3)(b) of the Fair Housing Act); Iowa Code § 216.8A(3)(c)(2).
- 6) Respondents acknowledge the FHA and ICRA make it unlawful to discriminate against another person in the terms, conditions, or privileges of sale or rental of a dwelling or in the provision of services or facilities in connection with the dwelling because of a disability. 42 U.S.C. 3604(f)(2)(a) (§ 804(f)(2)(a) of the Fair Housing Act); Iowa Code § 216.8A(3)(b)(1).
- 7) Respondents acknowledge as owners, developers, builders, or managers of covered multifamily dwellings – ground-floor units in buildings with no elevator or all units in buildings with an elevator, and consisting of four or more dwelling units built for first occupancy after January 1, 1992 – must build those dwellings in compliance with specific design and construction accessibility requirements, in accordance with the FHA and ICRA. Iowa Code §216. 8A(3)(c)(3); 42 U.S.C. §3604(f)(3)(C).

HUD has described these accessibility requirements via regulation and in several publications, including the “Final Fair Housing Accessibility Guidelines.” 24 C.F.R. Part 100.200 et seq.; 56 Fed. Reg. 9,472. In the “Guidelines,” HUD presented the seven specific requirements as:

Requirement 1 – Accessible building entrance on an accessible route.

Requirement 2 – Accessible and usable public and common areas.

Requirement 3 – Usable doors.

Requirement 4 – Accessible route into and through the covered dwelling unit.

Requirement 5 – Light switches, electrical outlets, thermostats and other environmental controls in accessible locations.

Requirement 6 – Reinforced walls for grab bars.

Requirement 7 – Usable kitchens and bathrooms.

#### *Voluntary and Full Settlement*

- 8) The parties acknowledge this Predetermination Settlement Agreement is a voluntary and full settlement of the disputed complaint. The parties affirm they have read and fully understand the terms set forth herein. No party has been coerced, intimidated, threatened or in any way forced to become a party to this Agreement.
- 9) The parties enter into this Agreement in a good faith effort to amicably resolve existing disputes. The execution of this Agreement is not an admission of any wrongdoing or violation of law. Nor is the execution of this Agreement an admission by Complainant that any claims asserted in her complaint are not fully meritorious.

10) The parties agree the execution of this Agreement may be accomplished by separate counterpart executions of this Agreement. The parties agree the original executed signature pages will be attached to the body of this Agreement to constitute one document.

11) Respondents agree the ICRC may review compliance with this Agreement. And as part of such review, Respondents agree the ICRC may examine witnesses, collect documents, or require written reports, all of which will be conducted in a reasonable manner by the ICRC.

*Disclosure*

12) Because, pursuant to Iowa Code §216.15A(2)(d), the ICRC has not determined that disclosure is not necessary to further the purposes of the ICRA relating to unfair or discriminatory practices in housing or real estate, this Agreement is a public record and subject to public disclosure in accordance with Iowa's Public Records Law, Iowa Code Chapter 22. See Iowa Code §22.13.

*Release*

13) Complainant hereby waives, releases, and covenants not to sue Respondents with respect to any matters which were or might have been alleged as charges filed with ICRC, the Office of Fair Housing and Equal Opportunity, Department of Housing and Urban Development, or any other anti-discrimination agency, subject to performance by Respondents of the promises and representations contained herein. Complainant agrees any complaint filed with any other anti-discrimination agency, including the Office of Fair Housing and Equal Opportunity, Department of Housing and Urban Development, which involves the issues in this complaint, shall be closed as Satisfactorily Adjusted.

*Fair Housing / Accessible Design and Construction Training*

14) Respondents agree to submit to ICRC the names of all employees who currently participate in the development, design, and/or construction of covered multifamily properties, as defined in "7)" paragraph on Page 9 of the current agreement, within 14 days from the date of the Closing Letter from ICRC. If there are no employees currently involved in the development, design, and/or construction of covered multifamily properties, Respondents agree to submit a signed statement to ICRC indicating this fact.

If any employee starts participating in the development, design, and/or construction of covered multifamily properties within one year from the date of the Closing Letter from ICRC, Respondents agree to notify ICRC of the change, including the names of any applicable persons, within seven days from the date of the change.

15) Respondents agree all persons identified in "14)" paragraph of the current section will:

(a) Receive training on the accessible design and construction requirements of State and Federal Fair Housing Laws. The training will address the Fair Housing accessibility requirements that must be met in order to design and build covered dwellings and common use/public areas that are accessible and usable to individuals with mobility and visual impairments.

The training shall be conducted by a qualified person, approved by ICRC or the U.S. Department of Housing and Urban Development. Additionally, attendance at one of the training events offered by Fair

Housing Accessibility First – information about which is available online at <http://www.fairhousingfirst.org/training/calendar.html> - will fulfill the requirement for this term.

(b) Complete the training pursuant to “(a)” paragraph above within 180 days of the date of the Closing Letter from the ICRC if currently developing, designing, and /or building covered multifamily properties.

(c) Complete the training pursuant to “(a)” paragraph above within 180 days of their first day of developing, designing, and /or building covered multifamily if not currently engaged in the aforementioned activities.

(d) All persons identified in “(14)” paragraph of the current section also agree to send documentation to ICRC, verifying the fair housing / accessible design and construction training has been completed, within ten days of completing the training.

16) Respondents agree all persons identified in “(14)” paragraph of the current section will:

(a) Review and become familiar with the Fair Housing Accessibility Guidelines, 56 Fed. Reg. 9472 (1991) and the United States Department of Housing and Urban Development, Fair Housing Act Design Manual, A Manual to Assist Builders in Meeting the Accessibility Requirements of the Fair Housing Act, (August 1996, Rev. April 1998), which may be obtained online at <http://www.huduser.gov/portal/publications/PDF/FAIRHOUSING/fairfull.pdf>.

(b) Submit separate signed written statements via email from each of the Respondents’ representatives named above in paragraph “(a)”, and their current employees or agents who are involved in the design and/or construction of covered multifamily-dwelling properties indicating:

- i. They have reviewed and become familiar with the Fair Housing Act Design Manual.
- ii. They understand what the Seven Main “Design Requirements of the Guidelines” are by listing them in the written statement.

(c) Complete the requirements in “(a)” and “(b)” paragraphs of the current section within 120 days of the date of the Closing Letter from the ICRC if currently developing, designing, and /or building covered multifamily properties.

(d) Complete the requirements in “(a)” and “(b)” paragraphs of the current section within 120 days of their first day of developing, designing, and /or building covered multifamily if not currently engaged in the aforementioned activities.

*Required Modifications or Retrofits*

17) Respondents agree to make the following modifications or retrofits to the subject property:

*Accessible and Usable Public and Common Use Areas – Parking Area*

(a) The parties agree that although both parking spaces and the adjoining access aisle – adjacent to the east of Building 5719 – meet the 2010 ADAAG’s dimensions for Van-Accessible parking spaces and access aisles, neither one of these parking spaces had the required signage designating it as “Van-Accessible.”

(b) The parties agree the height to the bottom edge of the signs designating the two parking spaces – described in “(a)” paragraph above – as reserved for persons with disabilities is less than the minimum height of 60” allowed by 2010 ADAAG.

(c) Respondents agree they will add “Van Accessible” signage such that the bottom edge of these signs is no less than the 60”-minimum allowed by 2010 ADAAG

(d) Respondents agree they will increase the heights of the existing signs at the parking spaces described in “(a)” paragraph above, such that the bottom edge of these signs is no less than the 60”-minimum height allowed by 2010 ADAAG.

(e) Respondents agree to complete the retrofit described in the current section within 60 days from the date of the Closing Letter from ICRC.

*Accessible and Usable Public and Common Use Areas – Mailboxes*

(a) The parties agree the mailbox compartments are unusable for someone in a wheelchair because the mailbox kiosks housing these compartments are installed no less than 36” behind a sidewalk curb – which exceeds the 24”-maximum depth allowed by ANSI 1986 for obstructions.

(b) Respondents agree to:

i. Move the mailbox kiosks to either the front edge of the curb adjacent to the current location or to the front of one of the buildings adjacent to an existing sidewalk, with sufficient clear floor space in front of the kiosk to allow for a parallel approach by someone in a wheelchair.

ii. Respondents agree they will coordinate with the United States Postal Services (USPS) Postmaster in Johnston, Iowa to rearrange the mailbox numbers of assigned to the ground-floor units at mailbox kiosks for Buildings 5705, 5713, and 5719 – such that all ground-floor units will have mailbox keyholes with midlines that do not exceed the maximum the 54-inch height – that is allowed because there is sufficient clearance for tenants who use a wheelchair to make a parallel approach.

iii. Respondents agree to complete the retrofit described in the current within 60 days from the date of the Closing Letter from ICRC.

*Light Switches, Electrical Outlets, Thermostats, and Other Environmental Controls in Accessible Locations – Thermostats*

(a) The parties agree the height of the top thermostat controls in all inspected units exceed the maximum height of 48”, as allowed by the Manual.

(b) Respondents agree they will vertically relocate the thermostats in all units to a lower height, such that the display screen and all operating buttons do not exceed maximum height of 48”, as required by the Manual.

(c) Respondents agree they will complete the retrofit described in the current subsection at all ground-floor units within one year from the date of the Closing Letter from ICRC or sooner if requested by a tenant with a disability.

### *Usable bathrooms – Bathroom Sinks*

- (a) The parties agree the heights to the top of the rim at the sink of the Specification-B (Master) bathrooms<sup>19</sup> - which have removable vanity cabinets – of all inspected units, were measured at more than the 34”-maximum height for sinks at Specification-B bathrooms with removable cabinets, as required by the Manual.
- (b) Respondents agree they will replace the removable vanity cabinets with shorter removable vanity cabinets at the Specification-B bathrooms of all ground-floor units in Buildings 5705, 5713, and 5719, such that the height to the top of the rim of the bathroom sink will be no more than 34” above the finished floor as required in the Manual, and as shown in page 5 of the current agreement.
- (c) Respondents agree they will complete the retrofits described in the current subsection at all ground-floor units within one year from the date of the Closing Letter from ICRC or sooner if requested by a tenant with a disability.

### *Usable Bathrooms – Towel Bars*

- (a) The parties agree bathroom towel bars in all inspected units are unusable for persons using wheelchairs because they are installed at a height of 54 ½” above toilets that have a depth of 28” – which exceeds (i) the 54-inch maximum height if there is sufficient clearance for persons who use a wheelchair to make a parallel approach; and (ii) the 24”-maximum reach depth over obstructions, as allowed by ANSI 1986.
- (b) Respondents agree they will reinstall the towel bars at a height of no greater than 54 inches on a different wall away from the toilets in the bathrooms of all ground-floor units – such that there is sufficient clearance for persons who use a wheelchair to make a parallel approach – as required by ANSI 1986.
- (c) Respondents agree they will complete the retrofits described in the current subsection at all ground-floor units within 60 days from the date of the Closing Letter from ICRC.

### *Required Timelines for Completion of Modifications or Retrofits*

- 18) Respondents agree to notify all current tenants, via a letter, within 60 days from the date of the Closing Letter from ICRC about the option to make a reasonable accommodation request because of a disability for any of the above-required modifications or retrofits in their units, at no charge to the tenants.
- 19) Respondents agree to complete all retrofits requested as a reasonable accommodations within 14 days from the date the request is submitted by the tenant.
- 20) Respondents agree, for any tenant who makes a reasonable modification request that concerns one or more of the above-required modifications or retrofits, they will allow the tenant to make the decision whether the above-required modifications or retrofits are made during their tenancy. Respondents also agree those tenants who make that decision will be allowed to remain in their units while the renovations are being completed, so long as their continued stay is safe and does not unduly disrupt the renovation work. If their continued stay is not safe or unduly interferes with renovation work, Respondents agree to move the

---

<sup>19</sup> See Manual at page 7.37 for Specification-B bathroom example.

affected tenants to another suitable unit on a temporary basis, until the unit is made safe or the renovation work is completed. Respondents agree to pay all costs generated by such move.

*Mandatory Reports*

18) Respondents agree to notify ICRC when they have completed the required modifications or retrofits for each of the units and the public and common use areas. Such notification shall be made within 90 days of completion. These required notifications to ICRC after each unit or common area is modified or retrofitted will continue until all required modifications or retrofits have been completed in all applicable units.

19) Respondents agree to send a copy to ICRC (Attn: Emigdio Lopez-Sanders; Iowa Civil Rights Commission, 400 East 14<sup>th</sup> Street, Des Moines, Iowa 50319-0201) of all written reasonable accommodation requests for the above-required retrofits and modifications received within one year from the date of the Closing Letter from ICRC.

20) Respondents agree, as the required modifications or retrofits are made to a particular unit, ICRC may then inspect such unit, and then report the results of its inspection, addressing any outstanding deficiencies, in writing and within 30 days of the inspection, to Respondents. If the inspection indicates outstanding deficiencies, Respondents shall correct all such deficiencies within a reasonable period of time as determined by ICRC.

21) The sale or transfer of ownership, in whole or in part, by any owner of the subject property will not affect any obligation to modify or retrofit the subject property as specified in this Agreement, unless Respondents have obtained, in writing, as a condition of sale or transfer, the purchaser or transferee's commitment to be bound by the terms of this agreement to complete all required modifications or retrofits as specified in this Agreement.

---

Johnston Merle Hay & 57th, L.L.C.  
RESPONDENT

---

Date

---

Dallenbach Larson Development, L.L.C.  
RESPONDENT

---

Date

---

Aller Design Group, L.L.C.  
RESPONDENT

---

Date

---

Angela Jackson, Commissioner  
COMPLAINANT

---

Date

---

Kristin H. Johnson, Executive Director  
IOWA CIVIL RIGHTS COMMISSION

---

Date